

Verso CF 2500 F C5

Nominal air flow according to ErP 2018, m ³ /h	2542
Nominal air flow according to ErP 2018, l/s	706
Electric air heater capacity, kW / Δt, °C	7,5/8,3
Supply voltage HE, V	3~400
Supply voltage HW, V	1~230
Maximal operating current HE, A	16,9
Maximal operating current HW, A	6,3
Power supply cable E, mm ²	5×2,5
Power supply cable W, mm ²	3×1,5
Electric power input of the fan drive at maximum flow rate, W	640
Noise power level, L _{WA} , dB(A)	62
Noise pressure level, L _{PA} , dB(A), (3 m)	51
Filters dimensions B×H×L, mm	888×430×96
Supply filter class	ePM1 60 (F7)
Exhaust filter class	ePM10 50 (M5)
Unit dimensions B×H×L, mm	2000×528×1850
Panel thickness, mm	45
Maintenance space, mm	620
Unit weight, kg	340

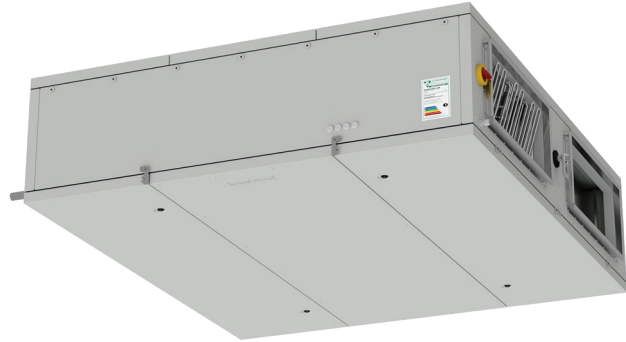

Performance

Verso CF 2500 F with standard equipment

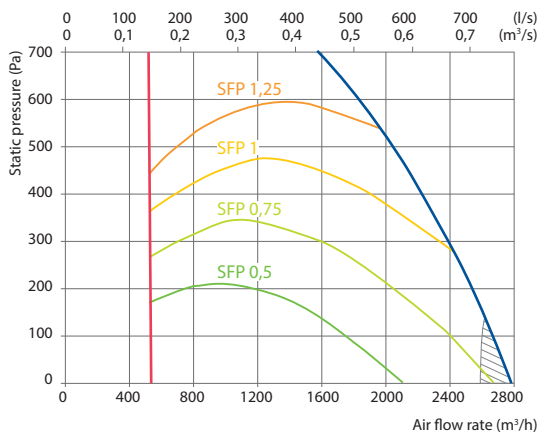

Does not conform to ErP2018 requirements

Accessories

Closing damper	SRU-M-700×300+LF24/LM24
Silencer	ODA/EHA STS-IVR3BA-800-300-700-S
	SUP/ETA STS-IVR3BA-800-300-1250-S
Water heater	SVK-700×400-2R
PPU	PPU-HW-3R-15-1,6-W2
Water cooler	DCW-2,5-17
2-way valve	VVP45.25-6,3+SSB161.05HF
DX cooler	DCF-2,5-17
Cooling unit for ducted cooler	MOU-55HFN8a+KA8142

Mounting positions



Temperature efficiency

Outside temperature, °C	Winter					Summer		
	-23	-15	-10	-5	0	25	30	35
After heat exchanger, °C	13,9	14,9	15,9	16,6	17,6	22,6	23,6	24,7

Indoor +22 °C, 20 % RH

Hot water duct air heater *

	Winter		
	80/60	70/50	60/40
Water temperature in/out, °C			
Capacity, kW	7,0	7,0	7,0
Flow rate, dm ³ /h	311	309	308
Pressure drop, kPa	4,8	4,8	4,9
Temperature in/out, °C	13,9 / 22		
Maximal capacity, kW	22,3	18,0	13,6
Connection, "	½		

* Option

Shown as right (R1)

View from inspection side

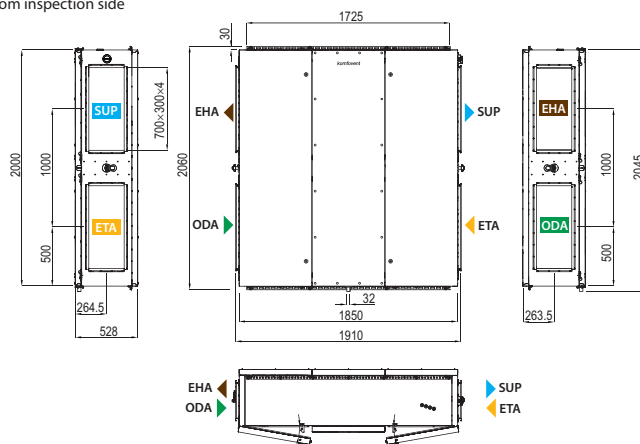

Shown as left (L1)

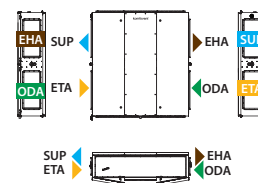

▶ ODA – outdoor intake ▶ SUP – supply air ▶ ETA – extract indoor ▶ EHA – exhaust air